

Measurements in inches(mm)

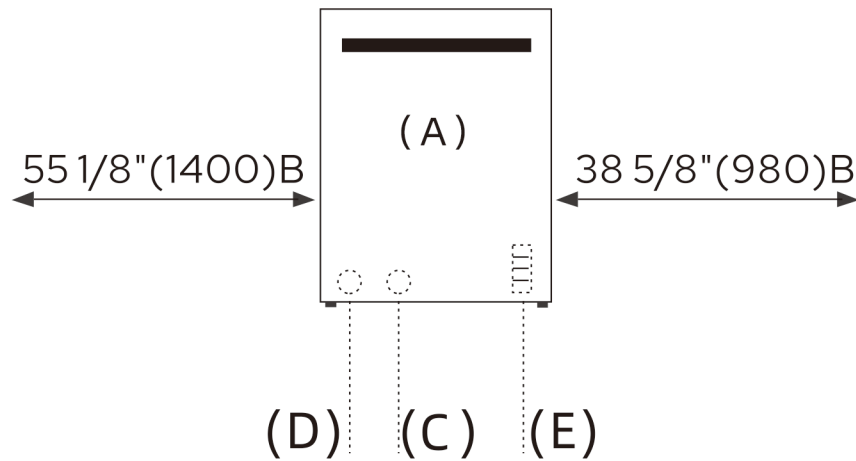

All connections are at the rear of the appliance. Extension for drain hose available as accessory.  
 Junction Box for hard wired connection available as accessory.

- A: Front view
- B: Drain hose
- C: Inlet
- D: Drain
- E:Electrical

# Water inlet valve

Picture



US size: G 3/4"-11.5

Inlet valve drawing

